

JABATAN PENGAIRAN DAN SALIRAN MALAYSIA

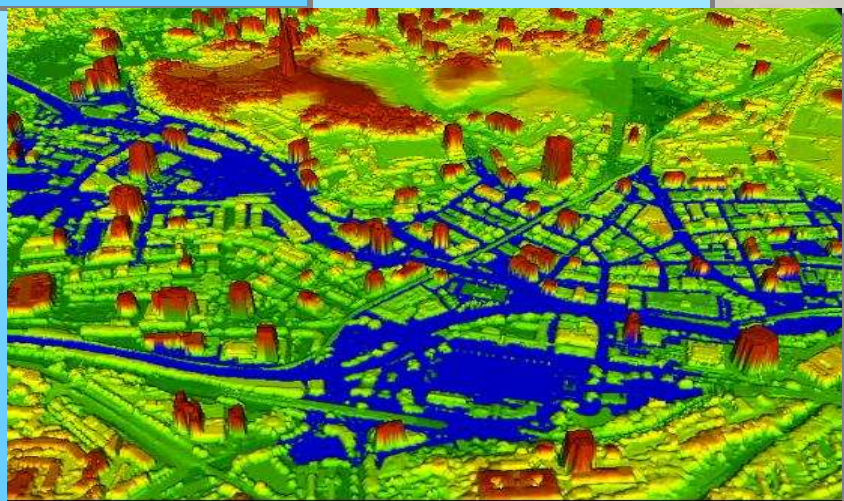

# GUIDELINE ON FLOOD PREVENTION FOR BASEMENT CAR PARKS

September 2006



## TABLE OF CONTENTS

---

---

<b>(A)</b>	<b>PURPOSE AND OBJECTIVES</b>	<b>1</b>
<b>(B)</b>	<b>BACKGROUND</b>	<b>1</b>
<b>(C)</b>	<b>COMPONENTS OF THE GUIDELINES</b>	<b>2</b>
<b>(1)</b>	<b>FLOOD RISK ASSESSMENT</b>	<b>3</b>
1.1	General Design Requirements	3
1.2	Hydrology Computation	5
1.3	Hydraulic Computation	5
1.4	Calculation Steps for Determining Flood Proofing Elevation (FPE)	6
1.5	Recommendation for Submission	6
<b>(2)</b>	<b>FLOOD PROOFING MEASURES</b>	<b>8</b>
<b>(3)</b>	<b>FLOOD SURVEILLANCE AND WARNING SYSTEM</b>	<b>9</b>
3.1	External Flood Surveillance System	9
3.2	Internal Flood Monitoring System	11
3.3	Car Park Flood Warning System	11
<b>(4)</b>	<b>EMERGENCY ACTION PLAN</b>	<b>11</b>
<b>(5)</b>	<b>INSPECTION AND MAINTENANCE PLAN</b>	<b>12</b>
<b>(6)</b>	<b>REFERENCES</b>	<b>14</b>
<b>ATTACHMENTS</b>		
Attachment 1	- General Recommendation for Submission	A1-1 – A1-3
Attachments 2	- Flood Proofing Measures for Basement Car Park	A2-1 – A2-7
Attachments 3	- Worked Example	A3-1 – A3-13

# **GUIDELINE ON FLOOD PREVENTION FOR BASEMENT CAR PARKS**

## **(A) PURPOSE AND OBJECTIVES**

The purpose of this Guideline is to provide the requirements and procedure for design and provision of flood proofing measures and flood surveillance and warning system for basement car parks of new buildings as well as existing buildings that do not meet with the requirements as outlined in this guideline. The Guideline also includes a worked example of the application submission format and design considerations.

The objectives of the proposed flood proofing measures and surveillance and warning system for basement car parks are as follows:

- To prevent or to reduce the flooding occurrence of basement car parks;
- To prevent the loss of lives in the event of flooding of basement car parks; and
- To reduce the damages due to flooding of basement car parks.

## **(B) BACKGROUND**

Basement car parks constitute an important component of metropolitan infrastructure as daily influx of urban workers and city dwellers require large number of parking facilities. Basement car parks will continue to be built, especially for high rise buildings, in highly urbanized areas. However, in recent years, a number of basement car parks have been flooded due to river over spilling and urban flash floods. Great losses have been inflicted upon property owners and hundreds of car owners. Moreover, lives were at stake during these flooding incidences.

Recognizing that urbanization will continue to take place in Malaysia and high rise buildings and basement car parks will continue to be built, it is pertinent that guidelines on flood prevention for basement car parks be developed with a view to minimize property damage and to prevent loss of lives.

The Malaysian Cabinet's decision on 10 September 2003 proposed that all basement car parks shall be provided with flood gates so as to prevent flooding of the car parks. Subsequently the Department of Town and Country Planning (Peninsular Malaysia) has developed Planning Guidelines JPBD 7/2003 entitled "Planning Standards and Guidelines: Multi-storey Car Parks". The said guidelines stipulate that all basement car parks of new buildings in the Kuala Lumpur City area must be provided with flood gates before construction approval can be given by the Authorities.

The Architecture Division of the Public Works Department (PWD) in June 2006 published the Second Edition of "Garis Panduan Reka Bentuk Parkiran (Tempat Letak Kereta) Bawah Tanah Kalis Banjir". The PWD guidelines consist of 2 main parts. Part 1 deals with the planning criteria on car park space, location, arrangement, traffic and instruments. Part 2 presents the guidelines on the design of flood proofing of underground car park which covers the requirements for flood record analysis, flood warning systems, security and access, flood emergency operation plan, as well as inspection and maintenance plan. The guidelines also cover various flood proofing design methods and application techniques.

This guideline, initiated by the Department of Irrigation and Drainage (DID), focuses on aspects pertaining to flood risk assessment, hydraulic computations, flood surveillance and warning systems, and emergency action plan. The provision of this guideline is to assist the Approving Authorities to check and approve the flood proofing proposal submitted by the consultant appointed by the building owner. General recommendation for submission to the authorities and examples of flood proofing measures are included for illustration purpose.

### **(C) COMPONENTS OF THE GUIDELINES**

The Guidelines consists of the following components:

- Flood Risk Assessment
- Flood Proofing Measures

- Flood Surveillance And Warning System
- Emergency Action Plan
- Inspection And Maintenance Plan

## **1. FLOOD RISK ASSESSMENT**

Flood Risk Assessment (FRA) is required to assess the flooding potential as well as flood depth and flood proofing elevation (FPE) at the entrance/exit point of the basement car park with respect to the design flood level at the main drain or river system. The assessment process would require hydrologic and hydraulic computation to be performed to determine the flood level and FPE at the entrance/exit point of the basement car park.

### **1.1 General Design Requirements**

For all new buildings with basement car parks, the elevation of the entrance/exit to the basement car parks shall be:

- Not lower than 1 meter above the 100-year ARI flood level;
- or
- Not lower than 0.5 meter above the 200-year ARI flood level.

If the above criteria cannot be fulfilled for reasons that cannot be avoided or for existing buildings where the entrance/exit level of the basement car parks cannot be raised to meet the above requirement, flood proofing measures are required based on the design guidelines and requirements stipulated below. In all circumstances, approval from relevant authorities and agencies is required.

The design requirements considered in deriving the FPE are as follow:

- For deriving FPE, the maximum flood depth calculated shall be based on either 100-year or 200-year ARI flood event with respect to the alternative to be adopted from Table 1.
- For new buildings, the maximum flood depth allows for flood proofing measures shall not exceed 1 meter for 100-year ARI flood event or 1.5 meter for 200-year ARI flood event; however, in unavoidable case, the building owners shall seek Authority approval in the preliminary planning to allow for greater flood depth to be adopted. The FPE to be adopted shall refer to Table 1 and Figure 1.
- For existing buildings, the maximum flood depth allows for flood proofing shall be the full flood depth computed based on the existing drainage system and the FPE adopted from Table 1 and Figure 1.

Item	Description	Alternative 1 (100-Yrs ARI Flood Level)	Alternative 2 (200-Yrs ARI Flood Level)
1	FPE Adopted At The Entrance /Exit Point of Basement Carpark	FPE = CFL + 1m	FPE = CFL + 0.5m
2	Allowable Maximum Flood Depth For Flood Proofing Measures for a new building	< 1m	< 1.5m
3	Allowable Maximum Flood Depth For Flood Proofing Measures for an existing building	Full Flood Depth Computed	Full Flood Depth Computed

Note : CFL - Computed Flood Level at the entrance / exit point of the basement carpark

Table 1 –Determination of Flood Proofing Elevation And Criteria For Allowable Maximum Flood Depth

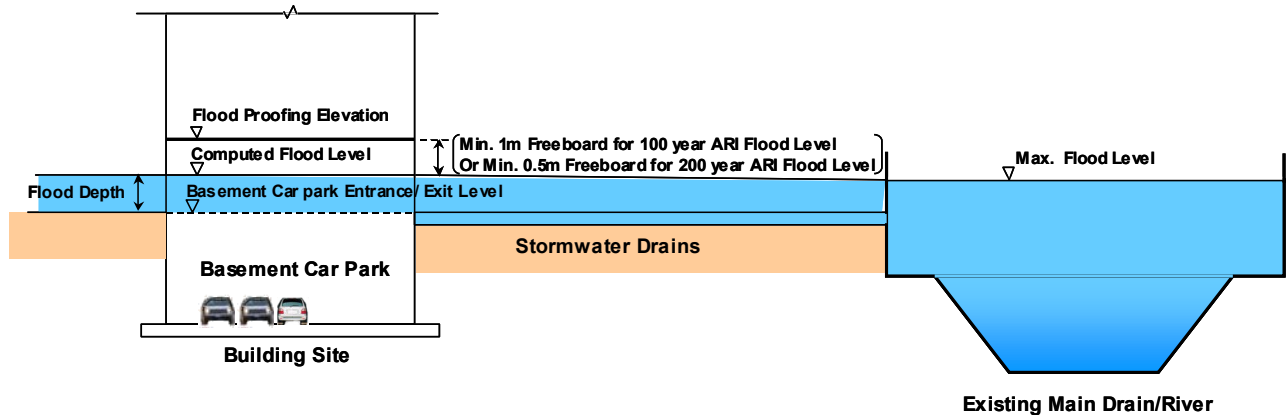

Figure 1 – Illustration of The FPE Design Requirement

## 1.2 Hydrologic Computation

The estimation of the design flood discharge for the drainage system shall be carried out based on methods described in Chapter 14 of MSMA Manual (DID, 2000). This is to facilitate the subsequent hydraulic computation to obtain the flood level at the entrance/exit point of the basement car park.

## 1.3 Hydraulic Computation

The calculation of flood levels for the drainage system shall be carried out based on hydraulic routing described in Chapter 14 of MSMA Manual. The analysis must take into consideration the backwater effects or tidal influence from the main stream and should ignore the existence of any flood bund at the main stream assuming that the bund has been breached or overtopped during the flood.

The hydraulic computation can be carried out using appropriate engineering software as highlighted in Chapter 16 and 17 of MSMA Manual.

### **1.4 Calculation Steps For Determining Flood Proofing Elevation (FPE)**

Once the drainage system for the building has been sized up, the PFE can be determined as follows:

- i) Determine the 100-Yrs or 200-Yrs ARI design flood discharge of the main drain/river depending on the alternative adopted by the designer;
- ii) Determine or obtain from the Authority the relevant design flood level of the main drain/river at the building discharge point;
- iii) With items (i) and (ii), carry out hydraulic routing to determine the flood level/depth at the entrance/exit point of the basement car park taking into consideration the backwater effect;
- iv) With the flood level, determine the FPE as prescribed in Table 1;
- v) Based on the FPE, select the suitable flood proofing measures for the building.

The flow chart in Figure 2 illustrates the foregoing procedure.

### **1.5 Recommendation for Submission**

It is recommended that the submission for the car park FRA shall consist of the following:

- Basement car park layout and cross sectional plans
- Stormwater drainage plan
- Stormwater drains longitudinal profile
- Hydrologic & Hydraulic computations
- Flood proofing measures shop drawings, calculations, installation and maintenance manual (endorsed by Professional Engineer)
- Flood Surveillance and Warning System
- Emergency Action Plan
- Inspection and Maintenance Plan

(Note: The details of the above submission are outlined in Attachment 1)

All the plans shall be duly endorsed by qualified personnel.



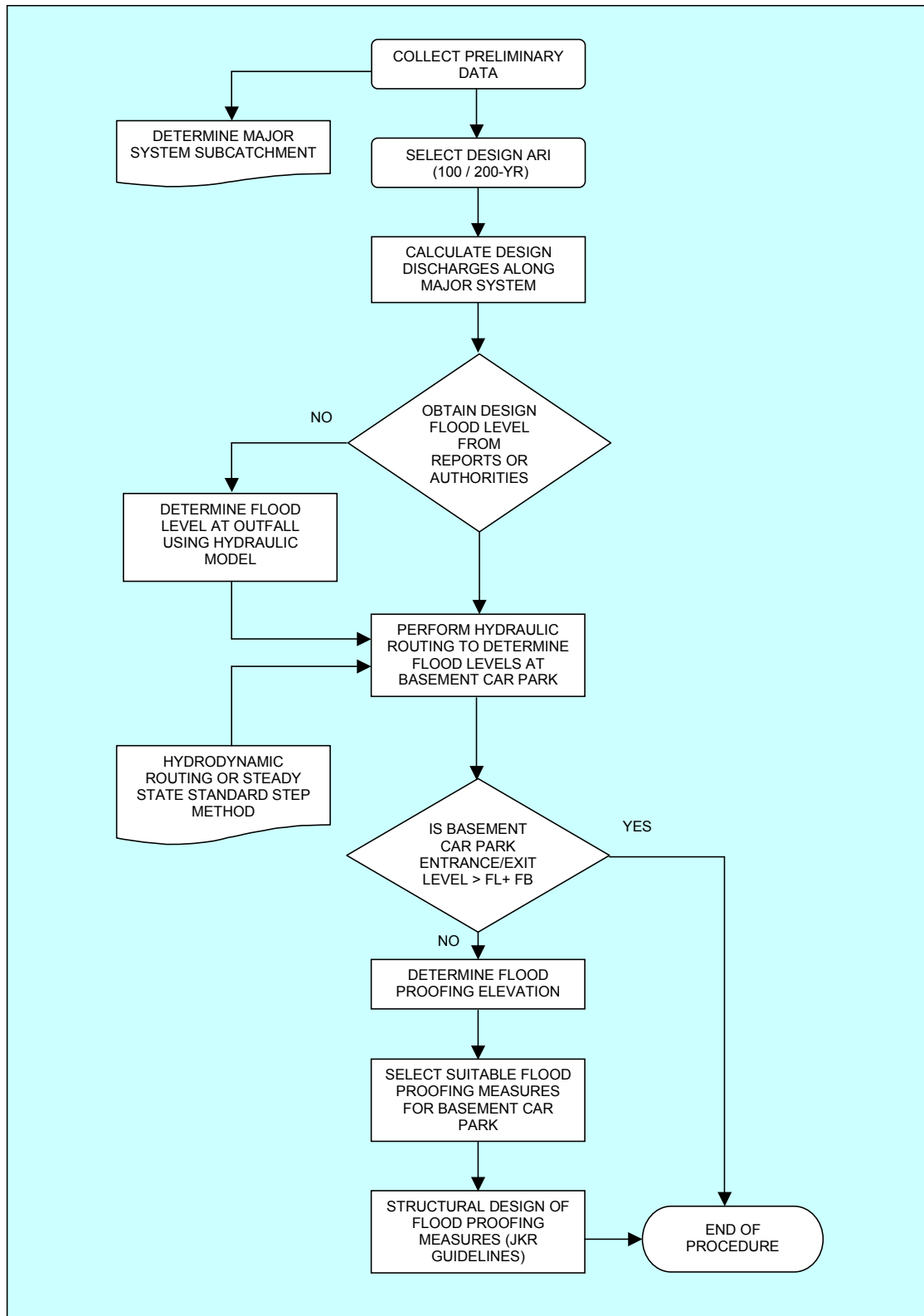

Figure 2 - Flow Chart for Determining Flood Proofing Elevation and Measures

## 2. FLOOD PROOFING MEASURES

The function of Flood Proofing Measures installed at a basement car park is mainly to prevent the intrusion of flood water into the car park area during a flood event. The measure that is commonly adopted in Malaysia is the installation of a floodgate, which comprises of a mechanical device system that can be set for automatic or manual closure when flood level exceeds critical level at the entrance/exit point of basement car park. The factors to be considered in designing the floodgate are as follows:

- The required speed of gate closure with respect to the rate of rise of flood water;
- The closure of the gates shall not be blocked by any structures or cars;
- The closure shields shall not block doors from opening when shields are in place (therefore necessary to check direction and distance that all doors swing);
- The size of the entrance/exit opening (vertical lifting gate is preferred for opening more than 3m wide);
- Installation requirement;
- All material used to fabricate the gate shall be durable and non-corrosive;
- All gates shall be designed to withstand the hydrostatic and hydrodynamic forces;
- The minimum design safety factor shall be 2;
- All gates are preferred to have flush sill to avoid tripping;
- Aesthetics
- Reasonable installation and maintenance cost

The types of floodgate that can be adopted are:

- Hinged type floodgate
- Sliding floodgate
- Lift-Out floodgate (stop log)
- Vertical lift floodgate

- Lift-Up floodgate
- Self-Closing floodgate
- Flood door

(Note: A brief description of the above gates is in Attachment 2)

As an alternative to floodgates, the designer can opt for raised ramp approach in which the existing ramp at the entrance/exit point will be raised to the required flood proofing level. This approach is applicable where space is not a constraint. Flood proofing measures using sand bags can also be considered if the depth between the FPE and the level of existing ramp at the entrance/exit point is small. (Refer to Attachment 2 for further explanation).

### **3 FLOOD SURVEILLANCE AND WARNING SYSTEM**

The Flood Surveillance and Warning System (FSWS) for a basement car park which is subject to potential flooding is an important measure to prevent loss of lives and to reduce property damage. Once the car entrance/exit ramp is flooded, large volume of flood waters rushing down the ramp at high speed is very dangerous to people and drivers in the basement car park. Hence, a system and mechanism for real-time surveillance of the potential flooding of the car park should be established.

It is recommended that the submission for the basement car park FSWS shall consist of the following:

- External flood surveillance system
- Internal flood monitoring system
- Car park flood warning system

#### **3.1 External Flood Surveillance System**

The external flood surveillance system is intended to provide early detection of potential flooding of the basement car park. Early flood detection is extremely useful for the activation of flood proofing measures (viz. closing of flood gates) and flood

warning system. The external surveillance system may comprise the following two components:

- Facilities to receive flood warning and heavy rainfall warning messages issued by Government Agencies (such as MMD, JPS and DBKL) via radio, TV, internet, SMS and any other appropriate means
- Real-time monitoring of the flood levels of river or main drain by the car park management personnel via manual observation of river gauge, CCTV or telemetry.

The Malaysian Meteorological Department (MMD) provides heavy rainfall warnings via its official website and such information are also disseminated through various radio stations. The Department of Irrigation and Drainage (JPS) displays the real-time rainfall and river level data for several hundred telemetric stations nation-wide through its website. JPS has also installed many flood warning sirens in flood prone areas to provide early flood warning before the river level reaches designated flood level. Kuala Lumpur City Hall (DBKL) has established a number of variable message boards (VMB) at strategic locations (for instance the STAR LRT Station at Masjid Jamek and Jalan Campbell at Wilayah Complex) to display real-time river level data and flood information. Flood warning dissemination systems via SMS have also been developed by several government agencies (JPS, DBKL, etc). The basement car park flood management team should establish a mechanism to access the heavy rainfall and flood level information.

The basement car park management could also establish a mechanism to monitor the water level of the river or main drain that may flood the car park. A reader can be deployed to manually observe the rising river level during heavy rainfall episodes. He shall report to the car park management once the river level exceeds a designated critical level. Currently a number of the buildings around Masjid Jamek area are monitoring the river level through manual readers. Car park management may also consider installing a CCTV targeting at the river staff gauge to obtain real-time river level information.

### **3.2 Internal Flood Monitoring System**

The car park must be provided with a system to monitor the condition within the car park (such as CCTV). The monitoring system shall be functional even in the event of power failure. Emergency lightings must be provided at sufficient locations, and to function for at least several hours with no electricity, so that flood conditions can be visible. The management may deploy personnel to patrol the basement car park and to report on flooding condition.

### **3.3 Car Park Flood Warning System**

In the event of impending car park flooding, early warnings must be disseminated to all the car owners, car drivers and people within the basement car park so that appropriate emergency actions and safety precautions can be taken. Warnings can be disseminated to users via automatic trigger sirens with voice warning messages, PA system, hailer, intercom system, telephones, SMS, or other established means. Basement car parks provided with flood proofing measures, such as flood gates and flood pumps, must be ready to operate without jeopardizing the safety of people. Clear signage indicating directions to safe evacuation routes must be installed in the basement car park. Hazard warning lights and sirens have to be installed for the evacuation of people in the car park.

The flood warning system is also required to be provided for those buildings with platform elevations higher than the design flood level in the flood prone area. Although flood gate system is not required for these building, it is necessary to alarm the building occupants of the surrounding condition during a flood event.

## **4 EMERGENCY ACTION PLAN**

The Emergency Action Plan (EAP) is intended to save lives and minimize property losses in an impending event of basement car park flooding. The EAP shall define and describe the following:

- EAP organization chart and team members
- Roles and responsibilities of the EAP team members
- Standing Operating Procedures (SOP)
- Notification Flow Chart
- Communication Directory
- Plans of car park, flood proofing measures and evacuation routes

The EAP for car park flooding may be adapted from an existing EAP for other types of hazards (fire, earthquake, building collapse, explosion, etc). Periodical review of the EAP and drill exercises must be conducted to ensure that every EAP team member is thoroughly familiar with the SOP.

The SOP in particular shall describe in detail out the following procedures:

- Flood surveillance
- Operation of the flood gates and other flood proofing measures
- Dissemination of flood warnings
- Evacuation of people and drivers in the basement car park
- Activation of safety mechanism (power shut down to prevent injury/death caused by accidental electrocution, etc)
- Operation of flood pumps
- Post-flood operation

For submission purpose, the EAP shall consist of all the components described above.

## **5 INSPECTION AND MAINTENANCE PLAN**

The flood proofing facilities would require periodic inspection and maintenance to ensure all the components can properly operate during a flood event. The Inspection and Maintenance Plan (IMP) shall describe all the necessary inspection and maintenance activities, including inspection intervals and repair requirements. Among the components that should be inspected as part of a yearly (as a minimum) inspection and maintenance schedule include the following:

- Flood shields and closures, to ensure that they fit properly and the gaskets and seals are working properly;
- Mechanical equipment of the gate, sumps, pump (if any) and generator (if any)
- To check for any gaps at the flood gate that may cause leakage

For submission purposes, the IMP shall consist of the components described above.

## 6 REFERENCES

1. “Garis Panduan dan Piawaian Perancangan Tempat Letak Kereta” by Jabatan Perancangan Bandar dan Desa
2. “Manual Saliran Mesra Alam Malaysia (MSMA)” by Jabatan Pengairan dan Saliran Malaysia
3. “Garis Panduan Reka Bentuk Parkiran (Tempat Letak Kereta) Bawah Tanah Kalis Banjir” by Jabatan Kerja Raya Malaysia, Cawangan Arkitek
4. “Pengurusan Keselamatan Kebakaran di Pejabat-Pejabat Kerajaan dan Swasta” by Jabatan Bomba dan Penyelamat, Malaysia



## **Attachment 1 – General Recommendation for Submission**

The documents submitted by the consultant appointed by the building owner shall consist of minimum but not limited to the following information for checking, comment and approval by the Authority:

a) Basement car park layout plan

The above plan shall consist of minimum but not limited to the following details:

- The proposed location of the car entrance and exit ramps from the basement car park
- The proposed locations of the exit doors from the basement car park to the floors above
- The proposed locations and type of flood proofing measures to be adopted
- The proposed elevations of the basement car parks
- The proposed elevation of the compound/road (outside the building) adjacent to/linking the entrance/exit ramp of the basement car park
- The proposed elevations of the compound surrounding the building

b) Basement car park cross sectional view

The cross sectional view of the basement car park shall consist of minimum but not limited to the following details:

- The proposed elevation of the basement car parks
- The proposed level of the compound/road (outside the building) adjacent to/linking the entrance/exit ramp of the basement car park
- The computed flood level at the entrance/exit ramp of the basement car park
- The proposed level/elevation of the flood proofing measure
- The proposed elevations of the compound surrounding the building

c) Stormwater drainage plan

The stormwater drainage plan shall consist of minimum but not limited to the following details:

- The proposed main and secondary stormwater drainage system including drain alignment, types and size of the proposed drains, drain gradients, drain invert levels at starting, intermediate and ending points of the drains and sump invert levels (when necessary).
- The proposed discharge point to the adjacent main river/drain system
- Catchment area of the drainage system

d) Stormwater drains longitudinal profile

The profile shall consist minimum but not limited to the following details:

- The existing left and right bank levels
- The existing drains/stream invert levels
- The top water level (based on the required ARI design storm)
- The proposed left and right bank levels
- The proposed drains invert levels
- Chainages
- Type of proposed drains
- All the incoming drains (location and invert levels)

e) Hydrologic and hydraulic computations

The computation shall consist minimum but not limited to the following:

- Design criteria such as rainfall intensity, runoff coefficient, method of calculation, return period adopted, etc)
- Hydrologic computation to obtain the design flood hydrograph for the drainage system
- Hydraulic computation to obtain the water level profile of the drainage system with respect to the existing main drain/river flood level

f) Flood Proofing Measures Shop Drawings (Endorsed by Professional Engineer)

The shop drawings shall consist of minimum but not limited to the following details:

- Layout and elevations (dimensional plans)

- Product components (including anchorage, hardware and finishes (if applicable))
  - Sections and details for all mountings and connections
  - Applicable material specifications
  - Load diagrams
- g) Calculation (optional for critical application) endorsed by the Professional Engineer verifying the flood proofing measures ability to withstand the design pressure loading.
- h) Installation and maintenance manuals for the flood proofing measures adopted
- i) Flood Surveillance And Warning System  
The information required to be submitted for the Flood Warning System (FSWS) shall consist of the following:
- External flood surveillance system for the basement car park
  - Internal flood monitoring system for the basement car park
  - Car park flood warning system
- j) Emergency Action Plan  
The information required to be submitted for the Emergency Action Plan (EAP) shall consist of the following:
- EAP organization chart and team members
  - Roles and responsibilities of the EAP team members
  - Standing Operating Procedures (SOP)
  - Communication directory
  - Plans of car park, flood proofing measures and evacuation routes

All the above related plans and design computations shall be endorsed by the consultant appointed by the building owner.

## **Attachment 2 - Flood Proofing Measures For Basement Car Park**

### **2.1 General**

Flood proofing measures will help to prevent floodwater from intruding into the basement car park; thus saving lives and properties from being ruined. The usage of these flood proofing measures especially in Kuala Lumpur city area has been spelt out in the “Garis Panduan Dan Panduan Piawaian Perancangan Tempat Letak Kereta Bertingkat.” Further information is also available in the “Garis Panduan Reka Bentuk Parkiran (Tempat Letak Kereta) Bawah Tanah Kalis Banjir” by JKR.

### **2.2 Types of Flood Proofing Measures**

Several types of flood proofing measures are available in the market and the selection of suitable devices depends on various factors such as costing, opening size, movement space constraint, installation requirement, etc.

The types of flood proofing measures that could be used in Malaysia as well as description on each type of the measures are listed below:

#### **2.2.1 Raised Ramp And Flood Wall**

Raised ramp could be used if the existing ground level at entrance/exit ramp to basement car parks is slightly lower than the required design flood level and sufficient space to raise the ramp. Existing ramp will be raised to the required flood protection levels with acceptable slope to avoid using any floodgates or other flood proofing measures. The main advantage is that no human intervention is required at times of flooding condition, no other flood proofing measures are required and practically no maintenance cost will be incurred. This approach is very much preferred as compared to flood gate if space is not a constraint.

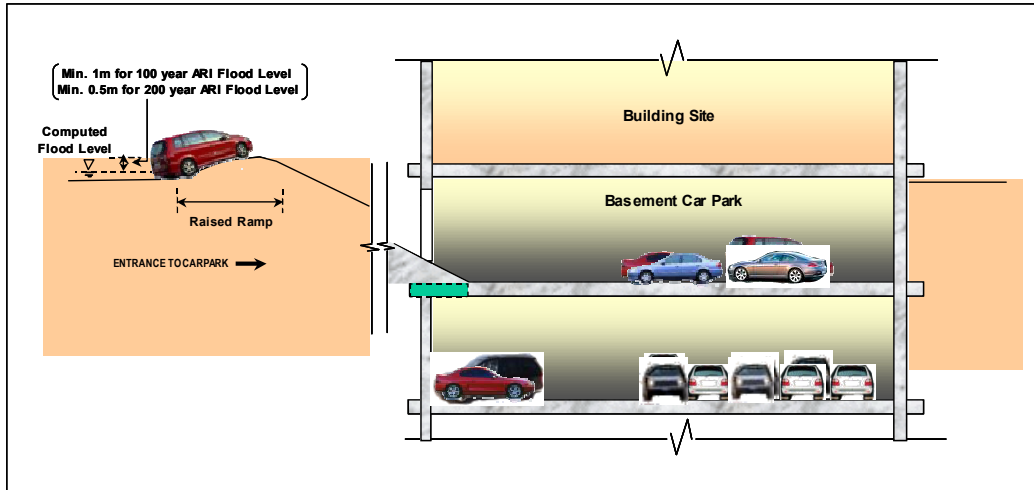

Raised ramp at building entrance



Floodwalls with entry and exit gates

### 2.2.2 Floodgates

- Hinged Flood Gates

Hinged Flood Gates are available in partial height or full height as well as single units or pairs. The gates have been manufactured to be used for small access hatch opening, pedestrian doors and roadway closures. Sills assemblies can be flush type, raised stop or recessed sills. These gates can be quickly and easily closed on short notice of flooding condition and minimum personnel is needed to place flood barriers when needed. Lift rollers could be installed for easy closing of large floodgates. The picture of a typical Hinged Floodgates (PS Doors product) is shown below: -



Hinged Type  
Floodgate

- Sliding Flood Gates

Sliding Gates can be designed to slide horizontally or vertically, and are a good selection when space is not available for the trajectory of a hinged gate. Sliding gates can be furnished in partial height or full-height. Sill can be flushed, or recessed with removable covers for pedestrian or vehicle traffic. Similar to hinged floodgates, this type of gates can be operated quickly and easily on short notice of flooding condition and minimum personnel is needed to place flood barriers when needed. The picture of a typical Sliding Floodgate (PS Doors product) is shown below: -



Sliding  
Floodgate

- Lift-out Flood Gates / Stop Logs

Lift out panels or stop logs offer an economical way to provide water protection on any size opening. These can be a permanent mount for service openings, or set in place at time of need only. Lifts out panels/ stop logs are a good selection when it is not desirable or possible to store the panels attached to the openings. The jamb assemblies can be embedded or surface mounted, and can be furnished in stainless steels if desired. These gates are generally lower in cost as compared to other types of gates and the remote storage of panels/shields does not require storage space at the opening area nor vanity covers to conceal the panels/shields for aesthetic reason. However, a safe storage facility is required for the panels/stop logs when they are not in use. The picture of a typical Lift Out Floodgate (PS Doors product) is shown below: -



Lift-Out  
Floodgate

- Vertical Lift Flood Gates

These gates are an alternative choice where conventional swinging, sliding and lift out floodgates are not the preferred choice or physical obstruction inhibit installation. These gates require minimum side rooms and they are excellent for large openings and automated operation. Gates operation is effected by hydraulic pressure or counterweighted for ease of operation or movement by hydraulic pressure. The pictures of typical Vertical Floodgates at Underground Car Parks (Kuala Lumpur) are shown below:



### Vertical Lift Floodgate

- Lift-up Floodgates

Lift-up floodgates are recessed into the floor and raised into place to provide protection during flooding condition. It has a flush sill assembly when in stored position, allowing for pedestrian or vehicle traffic. These gates can be operated quickly and easily on short notice of flooding condition and minimum personnel is needed to place the gates when needed. These gates are suitable for small openings with light vehicle loading to facilitate lifting mechanism and to avoid plate surface distortion that may lead to leakage problem.

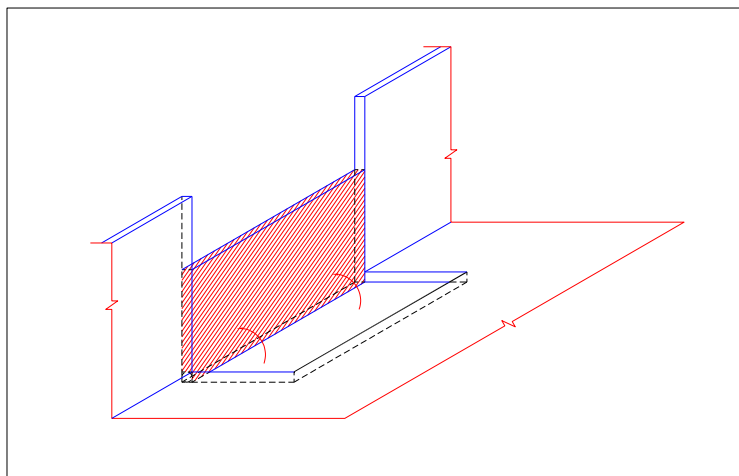

Lift-Up Floodgate



- Self-Closing Floodgates

Self-closing floodgates allow for automatic response to rising flood waters without any human intervention for operation. A typical example is that manufactured by PS Doors of U.S.A, which stores itself recessed into the ground and simply utilized the rising water to raise the watertight floodwall into place during flooding condition to provide protection without any external support (human, electricity, or other power). It has a flush sill assembly when in stored position, thus allowing for pedestrian or vehicle traffic. These gates are ideal for flash flood protection as closing time is very short and economical to operate as no operating staff is required. They are suited to a wide range of applications. The concept drawing of a Self-Closing Floodwall (PS Doors product) is shown below: -

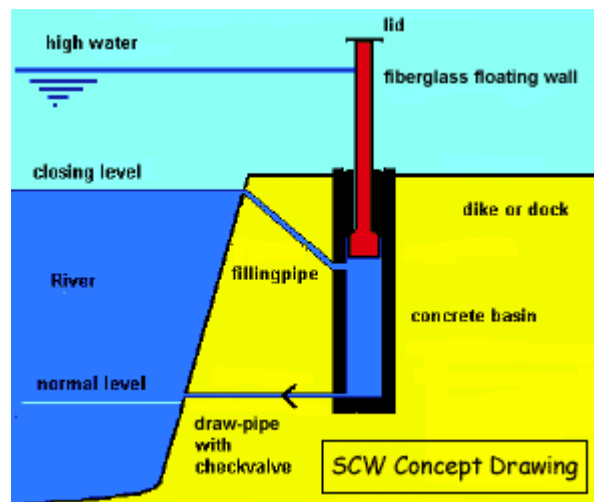

Self Closing Floodgate

Although these gates can be self operated, they are prone to clogging by rubbish and sediments that will jam the gate movement.

### 2.3.3 Pedestrian Flood Doors

Since pedestrian flood doors are always in place, no one needs to go and close the doors when flooding condition occurs, providing full time flood protection, while still allowing access to your facility on a daily basis. The doors usually come pre-hung on the frames ready to be installed and can be fitted with standard panic hardware, or an electronic keypad or card reader for accessing

the door. No human intervention is required at times of flooding condition. A typical Pedestrian Flood Doors from PS Doors is shown below: -



Flood Door

### **Attachment 3 - Worked Example**

This worked example is based on Appendix 16 A Worked Example in Chapter 16 of the MSMA. The purpose of this worked example is to demonstrate the typical method of computation to obtain the flood levels at the basement car park located at a small urban catchment (1.2 km<sup>2</sup>) at Sg. Rokam, Rapat Setia in Ipoh. A detailed description of the catchment is given in MSMA. The schematic layout of the existing main drainage system and sub-division of the catchment area are illustrated in Figure E1. As indicated in Figure E1, an existing basement car park is located near Node 6F1/4 of the drainage system at Sg. Rokam, about 500 m from the confluence with the main river Sg. Pinji. The elevation of the entrance and exit ramps to the basement car park is 37.8 mRL.

Although MSMA provides the computations of hydrological and hydraulic analysis using -XP-SWMM version 6.1 software to obtain the flood levels for the pre- and post-development conditions, only the hydrological analysis will be adopted for this worked example. Only the case for post-development condition will be considered. The computation of the backwater will be deferred example in order to demonstrate the steps to determine the flood levels after obtaining the design discharges along the drainage system.

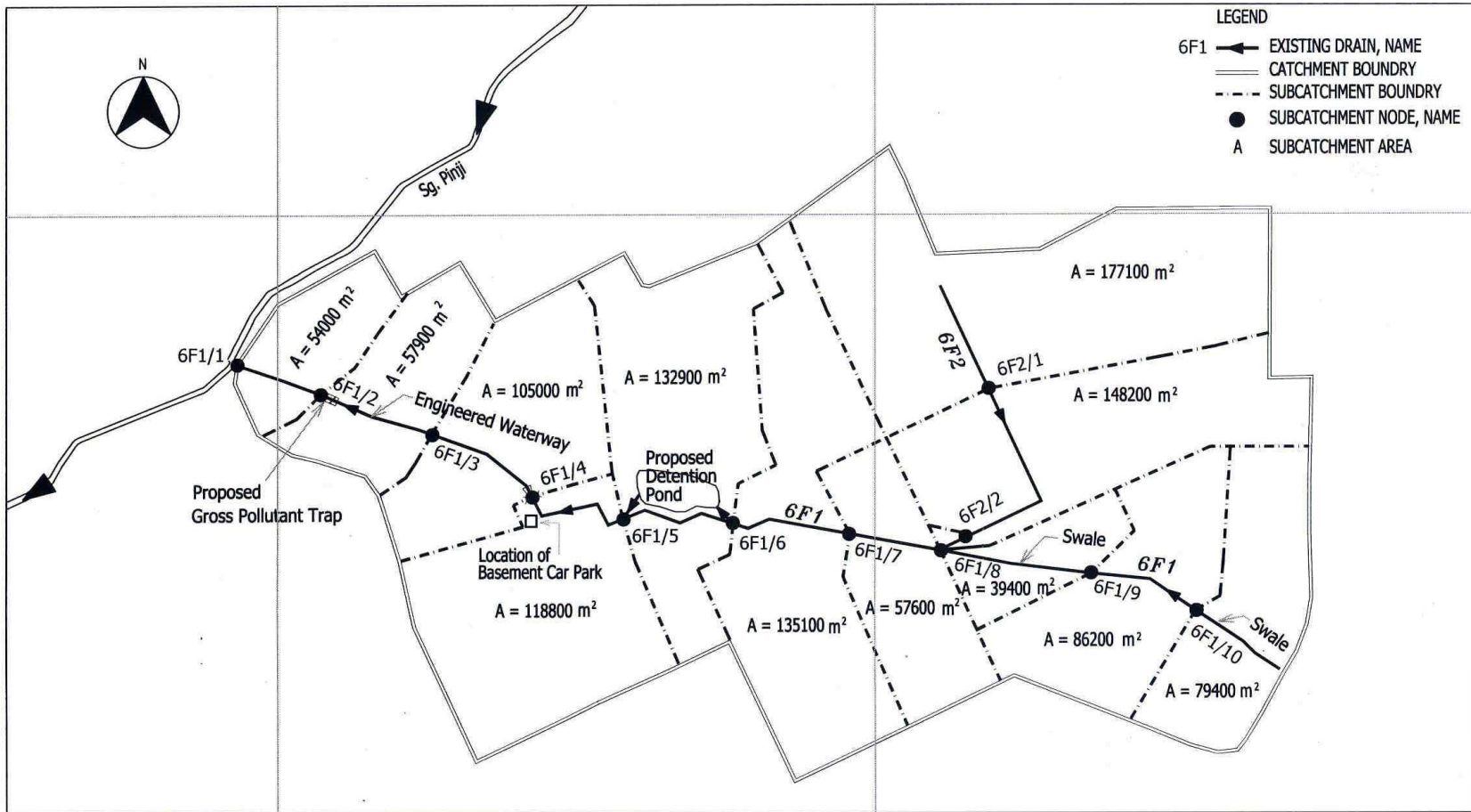

Figure E1 Schematic Layout of the Sg. Rokam Catchment and the Location of the Basement Car

a) *Hydrological Analysis*

The calculations were performed using XP-SWMM version 6.1 software. The design storms for the minor and major system corresponding to the 5 year ARI and 100 year ARI respectively under the post-development conditions are evaluated. The Time-Area method is used for generating the design hydrographs and the catchment details are as given in Table E1 (same as Table 16.A.5 in MASMA):

Table E1 - Catchment Details for Post-development

Node Name	Routing Method	Infiltration Method	Contributing Area (ha)	Impervious % (%)	Time of Concentration (min)	Slope % (%)
6F2/1	Time-Area.	Normal	17.71	50	20	1.0
6F1/10	Time-Area.	Normal	7.94	24	14	2.0
6F1/9	Time-Area.	Normal	8.62	36	13	1.3
6F1/8	Time-Area.	Normal	14.82	50	20	1.0
-	-	-	3.94	36	-	1.0
-	Time-Area.	Normal	-	-	14	-
6F1/7	Time-Area.	Normal	5.76	50	13	1.0
6F1/6	Time-Area.	Normal	13.51	50	14	1.0
6F1/5ds	-	-	-	-	-	-
Basin-us	-	-	-	-	-	-
Basin	Time-Area.	Normal	13.29	36	17	0.5
6F1/4A	-	-	-	-	-	-
6F1/4us	Time-Area.	Normal	11.88	36	15	0.5
6F1/4ds	-	-	-	-	-	-
6F1/3	Time-Area.	Normal	10.50	24	16	0.5
6F1/2	Time-Area.	Normal	5.79	24	13	0.5
6F1/1	Time-Area.	Normal	5.40	24	13	0.5
Outlet	-	-	-	-	-	-

The details of the parameters adopted in Table E1 are provided in MSMA. The drainage system details are as given in Table E2 (same as Table 16.A6 in MSMA) where the nodes are as given in Figure E1 :

Table E2 - Drainage System Details for Existing System

Link Name	U/S Node	D/S Node	No.	Type	Bottom Width (m)	Side Slope (Z)	Length (m)	IL u/s (m)	IL d/s (m)	Manning n
25	6F2/1	6F1/8	-	Trapezoidal	2.0	0	400	46.4	41.0	0.017
26	6F1/10	6F1/9	-	Trapezoidal	1.0	4	200	47.0	42.5	0.040
27	6F1/9	6F1/8	-	Trapezoidal	1.0	4	250	42.5	41.0	0.040
28	6F1/8	6F1/7	-	Trapezoidal	2.5	0	150	41.0	40.7	0.017
29	6F1/7	6F1/6	-	Trapezoidal	2.5	0	200	40.7	39.0	0.017
30	6F1/6	6F1/5ds	-	Trapezoidal	2.5	0	200	39.0	37.8	0.017
46	6F1/6	Basin-us	-	-	-	-	-	39.0	39.5	-
45	6F1/5ds	6F1/4A	-	Trapezoidal	3.0	0	60	37.8	37.6	0.017
47	Basin-us	Basin	-	Trapezoidal	1.0	4	200	39.5	39.5	0.025
41	Basin	6F1/4A	-	-	-	-	-	39.5	37.6	-
-	-	-	-	Circular	-	-	30	-	-	0.014
38	6F1/4A	6F1/4us	-	Trapezoidal	3.0	0	140	37.6	37.2	0.017
39	6F1/4us	6F1/4ds	-	-	-	-	-	37.2	37.1	-
-	-	-	2	Rectangle	1.5	-	10	-	-	0.014
-	-	-	-	Trapezoidal	10.0	5	5	-	-	0.025
32	6F1/4ds	6F1/3	-	Trapezoidal	10.0	4	200	37.1	36.6	0.025
33	6F1/3	6F1/2	1	Trapezoidal	10.0	4	200	36.6	36.0	0.025
34	6F1/2	6F1/1	-	Trapezoidal	10.0	4	200	36.0	35.3	0.025
36	6F1/1	Outlet	-	Trapezoidal	10.0	4	100	35.3	34.8	0.025

In the hydrological analysis, design peak discharges along the drainage system are obtained for the 5-year ARI and 100-year ARI 60-minute duration storms. Actually, various storm durations have to be tested to obtain the critical storm duration for the system. For this example, it is assumed that the critical storm duration is 60 minutes. Table E3 shows the derived designed peak discharges for 5-year and 100-year ARI 60-minute duration events. The results are adopted from Table 16.A7 and Table 16.A8 in MSMA. The design peak discharges for the 5-year and 100-year ARI events respectively are depicted on the schematic layout in Figure E2 and Figure E3 which are the same as Figure 16.A5 and Figure 16.A6 in MSMA.

Table E3 - 5-year and 100-year ARI 60 minute Storm for Post-development

Link Name	U/S Node	D/S Node	IL u/s (m)	IL d/s (m)	Manning n	Q <sub>max</sub> for 5-yr ARI (m <sup>3</sup> /s)	Q <sub>max</sub> for 100-yr ARI (m <sup>3</sup> /s)
25	6F2/1	6F1/8	46.4	41.0	0.017	6.50	9.54
26	6F1/10	6F1/9	47.0	42.5	0.040	3.09	4.64
27	6F1/9	6F1/8	42.5	41.0	0.040	5.83	7.63
28	6F1/8	6F1/7	41.0	40.7	0.017	17.98	24.38
29	6F1/7	6F1/6	40.7	39.0	0.017	19.98	27.19
30	6F1/6	6F1/5ds	39.0	37.8	0.017	18.35	24.72
46	6F1/6	Basin-us	39.0	39.5	-	-	-
45	6F1/5ds	6F1/4A	37.8	37.6	0.017	18.32	24.68
47	Basin-us	Basin	39.5	39.5	0.025	6.51	9.46
41	Basin	6F1/4A	39.5	37.6	-	-	-
-	-	-	-	-	0.014	5.08	6.56
38	6F1/4A	6F1/4us	37.6	37.2	0.017	21.65	29.00
39	6F1/4us	6F1/4ds	37.2	37.1	-	-	-
-	-	-	-	-	0.014	14.07	14.89
-	-	-	-	-	0.025	11.46	19.57
32	6F1/4ds	6F1/3	37.1	36.6	0.025	25.48	34.39
33	6F1/3	6F1/2	36.6	36.0	0.025	28.53	38.98
34	6F1/2	6F1/1	36.0	35.3	0.025	29.92	41.46
36	6F1/1	Outlet	35.3	34.8	0.025	31.40	43.83

*b) Backwater Computation using Standard Step Method*

The flood levels at the location of the basement car-park at Node 6F1/4 can be computed by using any hydraulic models or simple spreadsheet. In this worked example, the simple steady state standard step method is used assuming subcritical flow condition.

The computation process involves the following step:

1. Obtain the flood levels along the main river at the confluence of Sg Pinji and Sg Rokan;



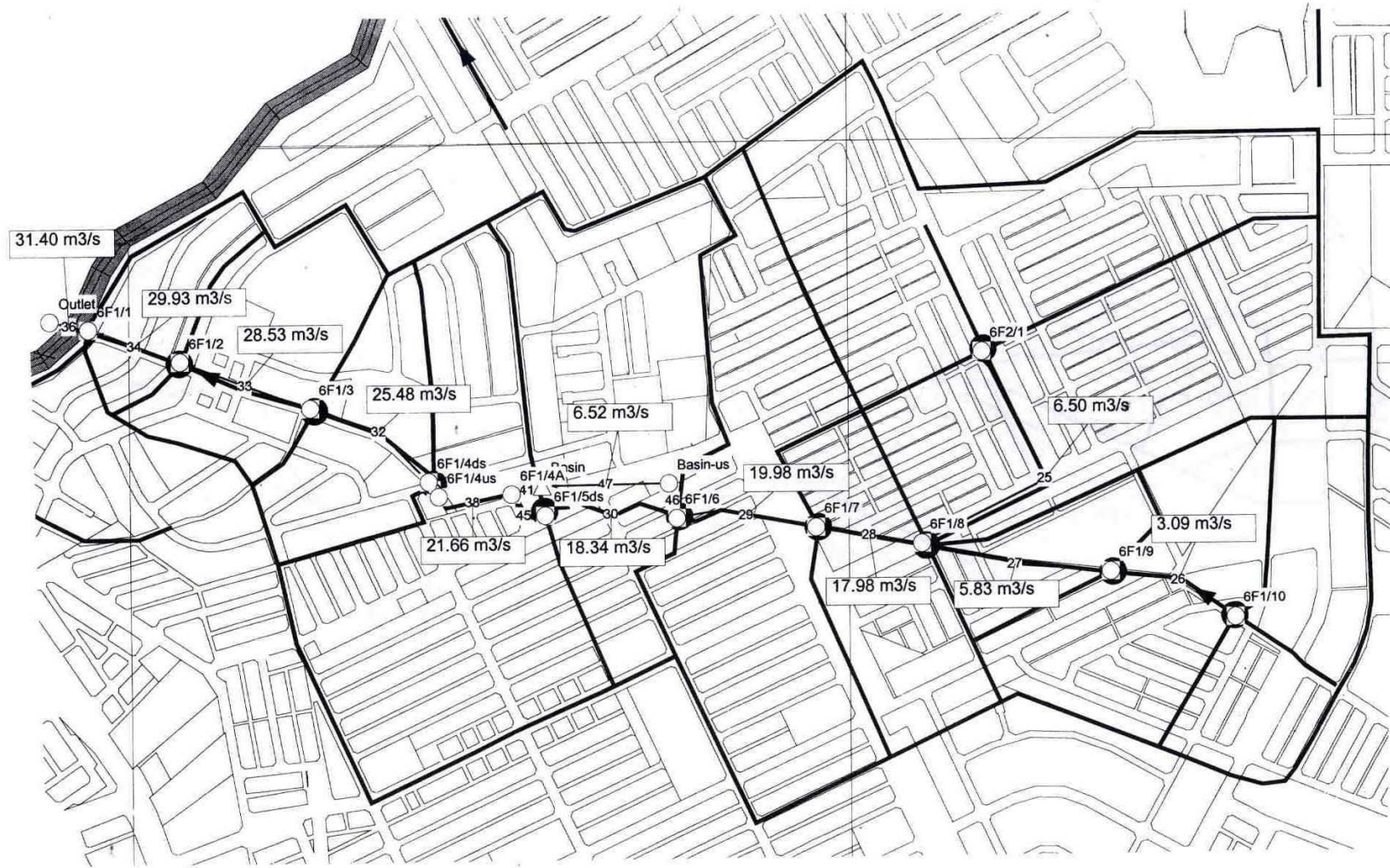

Figure E2 5-year ARI Design Peak Discharges along the Main Drainage System



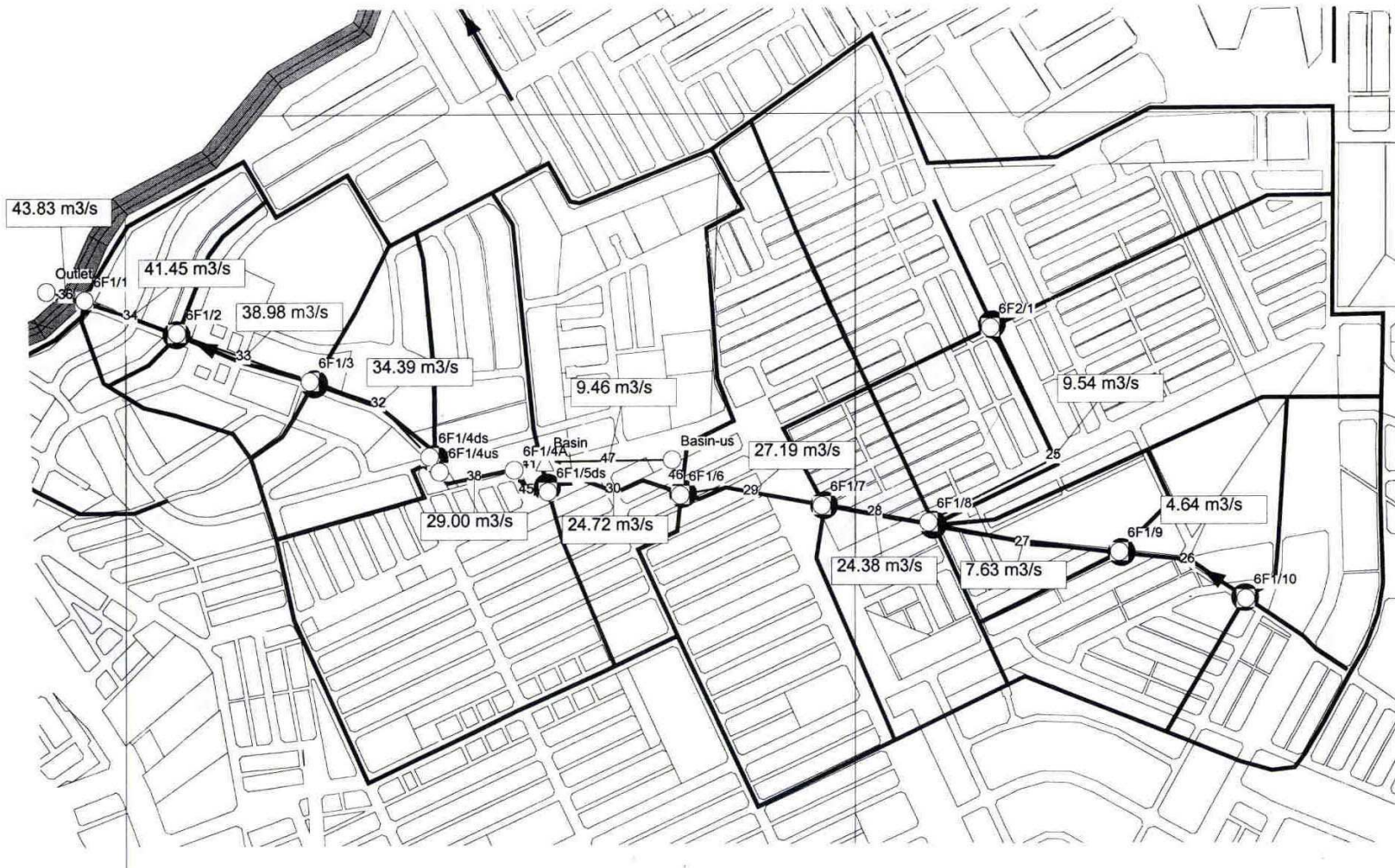

Figure E3 100-year ARI Design Peak Discharges along the Main Drainage System

2. Carry out the standard step method to estimate the flood levels at each node, starting from downstream to upstream for the 5-year and 100-year ARI events;
3. Obtain the flood levels for the 5-year and 100-year ARI events at the entrance/exit ramp of the basement car-park;
4. Compare the 100-year ARI flood level with the level at the entrance/exit ramp of the basement car-park based on the criteria stipulated in the Guidelines on Flood Loss Prevention Measures for Basement Car Parks;
5. If the level at the entrance/exit ramp of the basement car-park is lower than the 100-year ARI flood level, provide suitable flood proofing measure for the entrance/exit ramp of the basement car-park depending on the condition of flooding.
6. If floodgates are proposed, design the flood gates based on the forces stipulated in Appendix 1 of “Garis Panduan Reka Bentuk Parkiran (Tempat Letak Kereta) Bawah Tanah Kalis Banjir” by JKR.

1) *Flood levels at Sg. Pinji*

The flood levels for Sg. Pinji at the confluence with Sg. Rokam are assumed to be obtained from JPS and as given in Table E4.

Table E4 - Sg. Pinji Flood Levels at Confluence with Sg. Rokam

Average Recurrence Interval	Sg. Pinji Flood Level at Confluence with Sg. Rokam
5-year ARI	37.0 mRL
100-year ARI	38.0 mRL

## 2) Standard Step Method

Backwater surface profile is computed from one cross section to the next by solving the Energy equation with an iterative procedure called the Standard Step Method.

The Energy equation is written as follows :

$$Y_2 + Z_2 + \frac{\alpha_2 V_2^2}{2g} = Y_1 + Z_1 + \frac{\alpha_1 V_1^2}{2g} + h_e \quad (2-$$

- Where:  $Y_1, Y_2$  = depth of water at cross sections  
 $Z_1, Z_2$  = elevation of the main channel inverts  
 $V_1, V_2$  = average velocities (total discharge/ total flow area)  
 $\alpha_1, \alpha_2$  = velocity weighting coefficients  
 $g$  = gravitational acceleration  
 $h_e$  = energy head loss

Figure E4 illustrates the terms used in the Energy equation above.

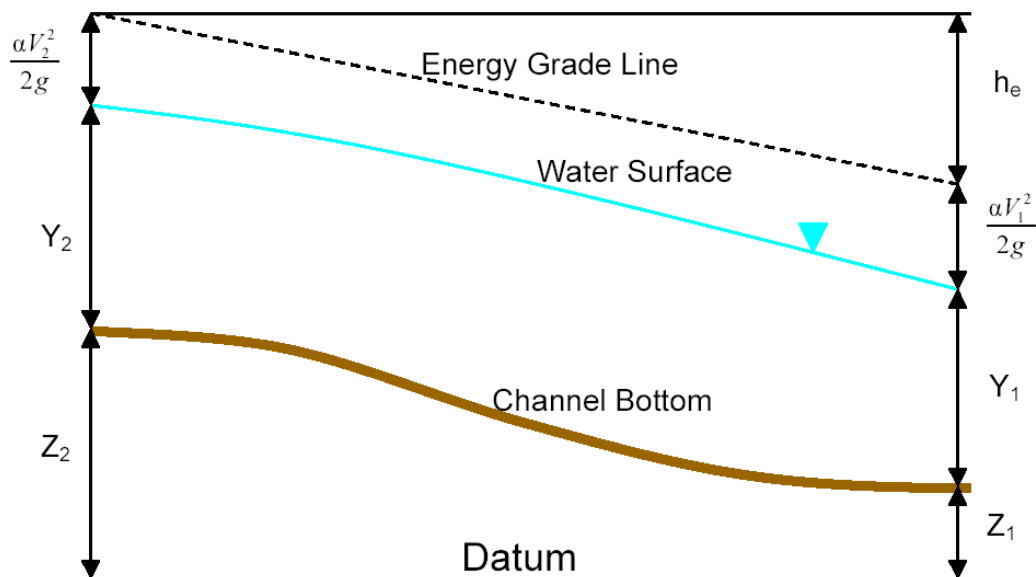

Figure E4 - Terms used in the Energy Equation for the Standard Step Method

In this example, the free software HEC-RAS version 3.2 is used for the computation. The definitions and derivations of all the terms are elaborated in the manual of the software.

### 3) Computation of Flood Profiles

Based on the channel dimensions and parameters for each node as well as the downstream flood levels at Sg. Pinji, the flood profiles can be computed using the Standard Step Method. The adopted expansion and contraction coefficients are 0.1 and 0.3 respectively. Table E5 and Table E6 show the layout of the spreadsheet computation using the Standard Step Method for 5-year and 100-year ARI events respectively.

Table E5 - Standard Step Method Computation Spreadsheet for 5-year ARI Event

U/S Node	Q <sub>max</sub> for 100-yr ARI (m <sup>3</sup> /s)	Surface Water Level (mRL)	Channel Velocity (m/s)	Velocity Head (m)	Friction Loss (m)	E & C Loss (m)	E.G. Elevation (mRL)
6F1/4ds	25.48	38.21	1.60	0.13	0.49	0.00	38.34
6F1/3	28.53	<b>37.67</b>	1.87	0.18	0.53	0.00	37.85
6F1/2	29.92	37.15	1.79	0.16	0.21	0.03	37.31
6F1/1	31.40	37.01	1.09	0.06	0.03	0.01	37.07
Outlet	31.40	37.00	0.77	0.03			37.03

Table E6 - Standard Step Method Computation Spreadsheet for 100-year ARI Event

U/S Node	Q <sub>max</sub> for 100-yr ARI (m <sup>3</sup> /s)	Surface Water Level (mRL)	Channel Velocity (m/s)	Velocity Head (m)	Friction Loss (m)	E & C Loss (m)	E.G. Elevation (mRL)
6F1/4ds	34.39	38.42	1.71	0.15	0.30	0.01	38.57
6F1/3	38.98	<b>38.13</b>	1.61	0.13	0.15	0.02	38.26
6F1/2	41.46	38.03	1.15	0.07	0.05	0.01	38.10
6F1/1	43.83	38.00	0.80	0.03	0.01	0.00	38.03
Outlet	43.83	38.00	0.62	0.02			38.02

Plots of the flood profiles along the Sg. Rokam are given in Figure E5 and Figure E6 for the 5-year and 100-year ARI events respectively. The flood levels obtained from the Standard Step Method backwater calculation are 37.67 mRL for 5-year ARI event and 38.13 mRL for 100-year ARI event

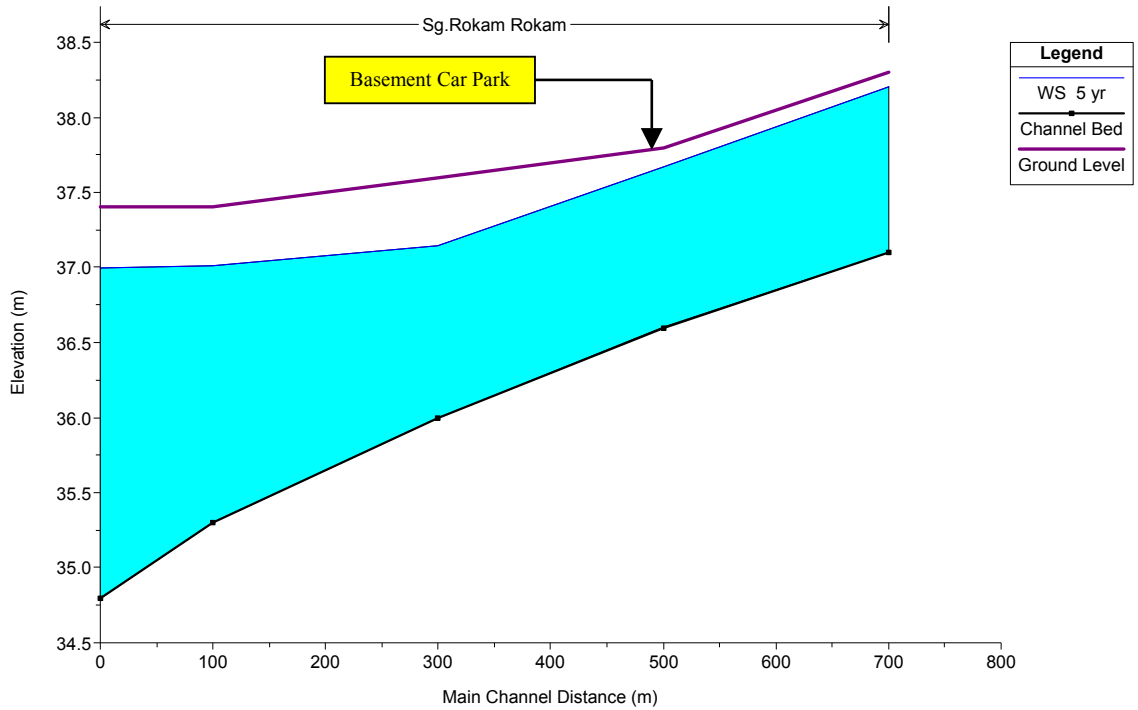

Figure E5 - Sg. Rokam Flood Profile for 5-year ARI Event

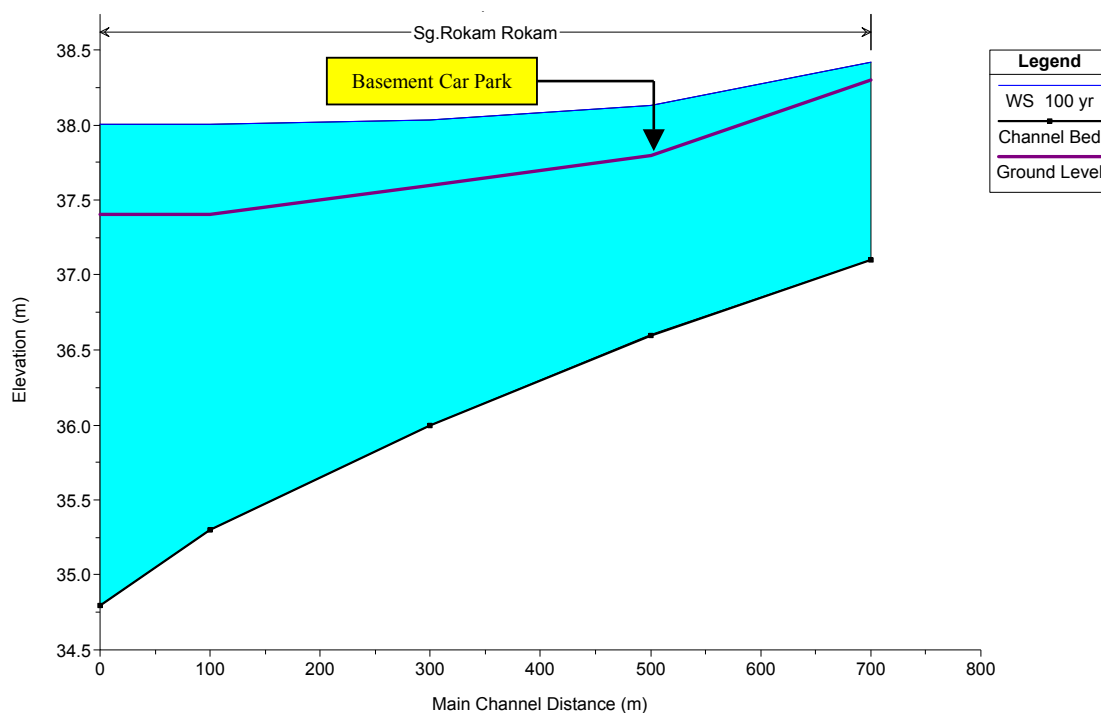

Figure E6 - Sg. Rokam Flood Profile for 100-year ARI Event

#### 4) Comparison of Flood Levels and Basement Car-park Levels

The levels at the entrance/exit of the basement car-park location around Node 6F1/4 is given as 37.8 mRL. This level is slightly higher than the 5-year ARI flood level which is 37.67 mRL. However, the 100-year ARI flood level is 38.13 mRL and it is higher than the entrance/exit level of the basement car park by 0.33 m. Flood proofing measures should be taken since the entrance/exit of the basement car park is prone to flooding based on the analysis carried out.

#### 5) Measures to be Adopted

Based on the guidelines, the entrance/exit level of the basement car park should be 1 m above the 100-year ARI flood level and thus should not be lower than 39.13 mRL. To raise the level at the entrance/exit of the basement car park to

39.13 mRL is not practical and flood proofing measure using flood gates is adopted here.

Lift-up floodgate is selected for this example and Figure E7 shows the section of the Lift-up floodgate arrangement.

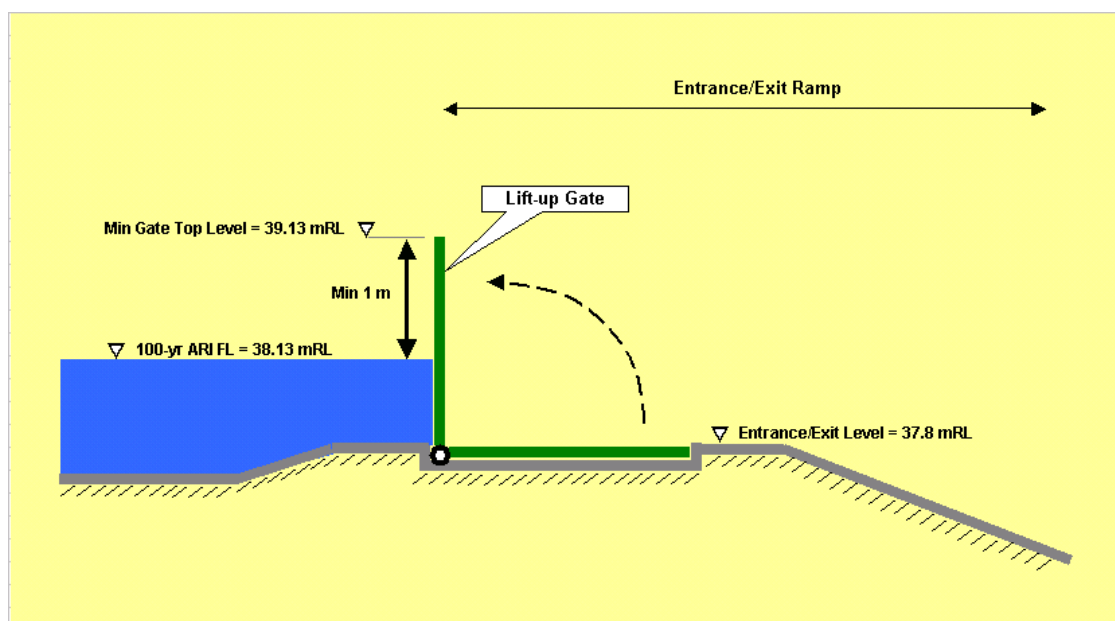

Figure E7 - General Arrangement and Dimension Requirements of the Lift-up Gate

#### 6) *Structural Design*

The structural design of the Lift-up gates should take into the consideration of all possible forces such as the hydrostatic force and hydrodynamic force. The detailed guidelines on this are provided in the “Garis Panduan Reka Bentuk Parkiran (Tempat Letak Kereta) Bawah Tanah Kalis Banjir” by JKR.